

### FRYERS

**Frymaster**

A WELBILT Company

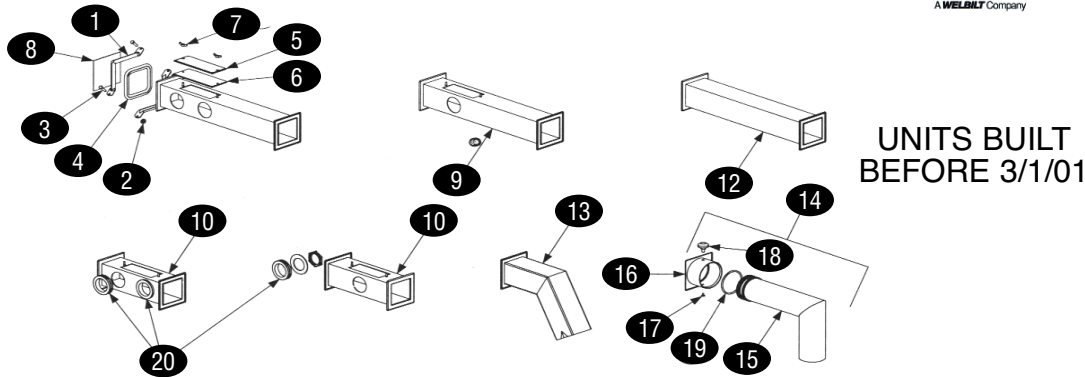

UNITS BUILT BEFORE 3/1/01

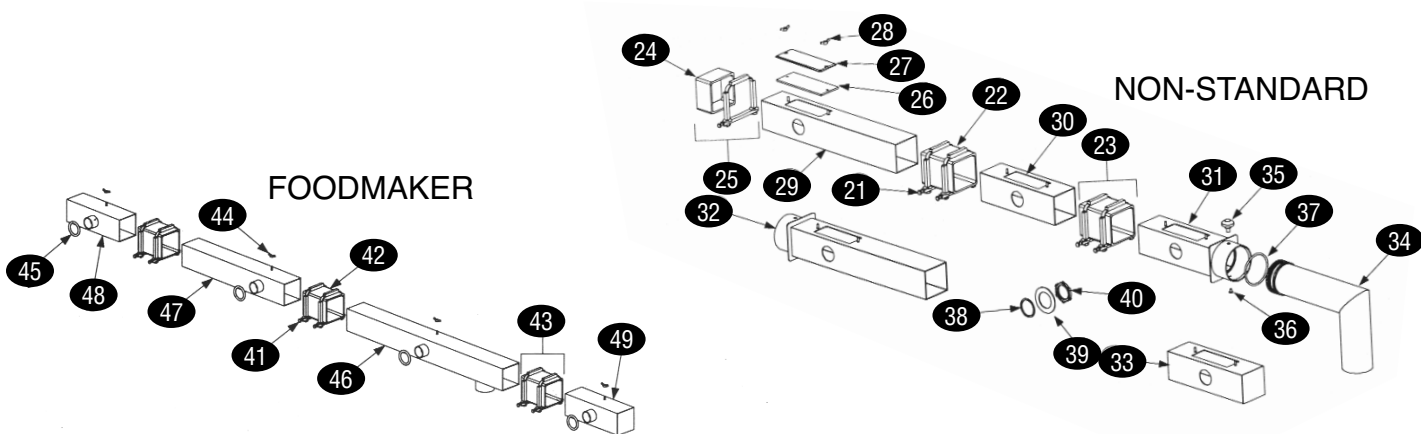

KEY	PART #	DESCRIPTION	KEY	PART #	DESCRIPTION
		– UNITS BUILT BEFORE 3/01 –			
1	FM810-0396	Clamp Section, requires 2 per connection	25	FMKIT-0256SP	Square Drain End Cap Kit
2	FM809-0071	Nut, 1/4"-20	26	FM816-0021	Cleanout Gasket
3	FM826-1375	Screw, #10-32x3/4"	27	FM900-0758	Cleanout Cover
4	FM816-0032	Seal, Connection Gasket	28	FM826-1382	Wing Nut, Cleanout Cover Retaining
5	FM826-1348	Cleanout Cover	29	FM823-1701	Drain Tube, Open Ends, 15"L
6	FM816-0021	Cleanout Gasket	30	FM823-2128	Drain Tube, Open Ends, 8.3"L
7	FM826-1382	Wing Nut, Cleanout Cover Retaining	31	FM823-1697	Drain Receiver, Swivel, Filter Left of Fryer
8	FM900-0757	Drain End Cover	32	FM823-1698	Drain Receiver, Swivel, Filter Right of Fryer
9	FM823-0717	Drain Tube, Full Vat, 15.5"L	33	FM823-1702	Drain Tube, Left End Close, 8.3"L
10	FM823-0718	Drain Tube, Full Vat Closed End, 8.12"L	34	FM823-1091	Drain Outlet, Swivel
12	FM823-0731	Spreader Cabinet Drain Tube Extension, 15.5"L	35	FM810-0388	Clamping Knob
13	FM823-0719	Drain Outlet, Fixed	36	FM809-0115	Screw, #10-3217
14	FM806-4068SP	Drain Outlet Swivel Assembly	37	FM816-0083	O-Ring, 2.5"
15	FM823-1091	Drain Tube, Swivel	38	FM816-0124	Fiber Washer
16	FM823-1092	Drain Collar	39	FM826-1345	Drain Tube Retaining Washer
17	FM809-0115	Screw, #10-32	40	FM809-0347	Drain Tube Retaining Nut
18	FM810-0388	Clamping Knob			– FOODMAKER UNITS –
19	FM816-0083	O-Ring, 2.5"	41	FM806-6374	Clamp Assembly
20	FM816-0092	Drain Tube Grommet	42	FM816-0420	Boot, Connection Seal
		– NON-STANDARD UNITS –	43	FMKIT-0257SP	Clamp Assembly and Seal Kit
21	FM806-6374SP	Clamp Assembly	44	FM826-1382	Wing Nut
22	FM816-0420	Boot, Connection Seal	45	FM816-0135	O-Ring
23	FMKIT-0257SP	Clamp Assembly and Seal Kit	46	FM823-2223	Open Drain Outlet Section, 23.38"L
24	FM816-0123	Square Drain End Cap	47	FM823-2301	Drain Section, 15.39"L
			48	FM823-2198	Right End Section, 7.95"L
			49	FM823-2222	Left End Section, 7.95"L

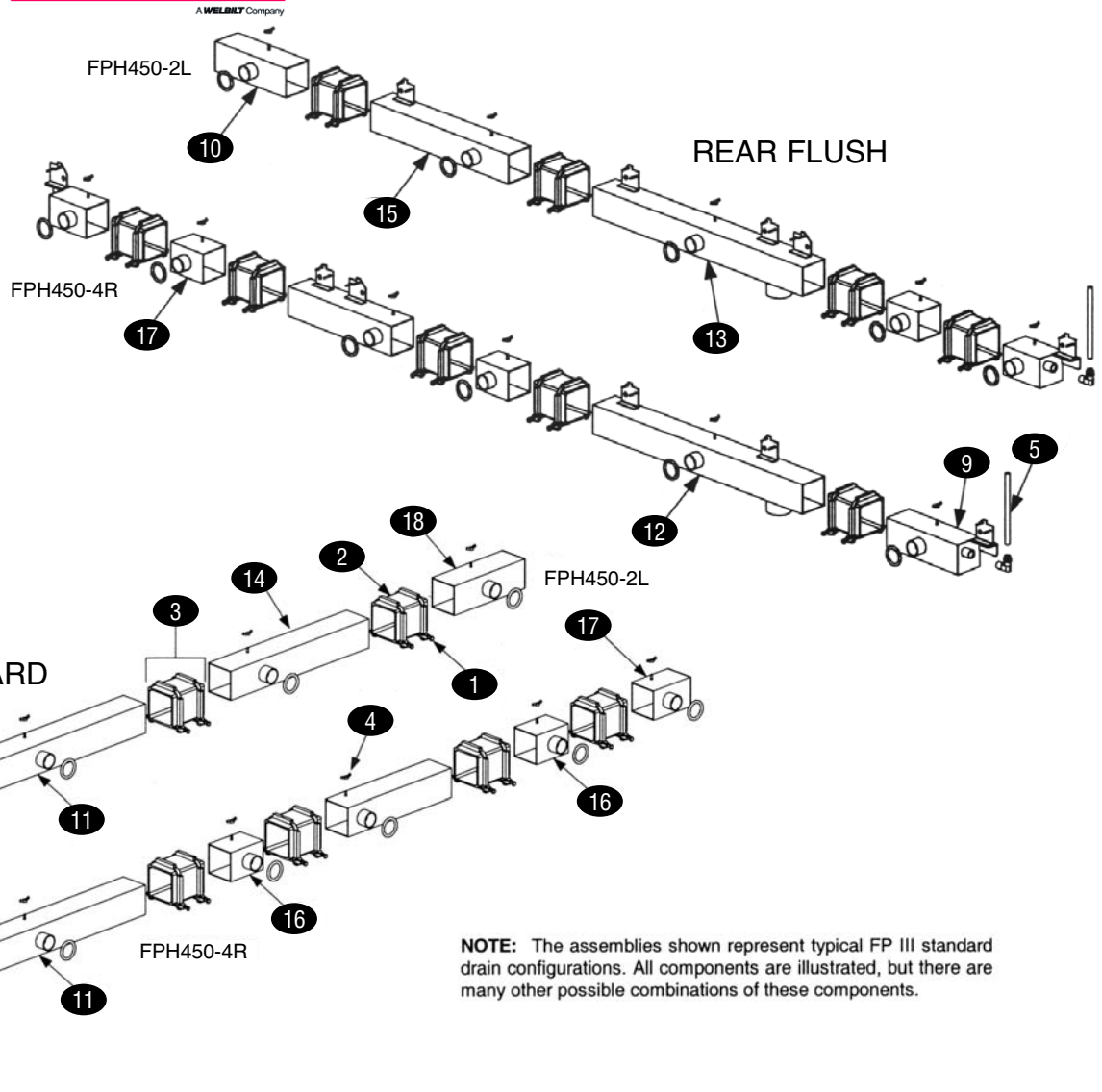

KEY	PART #	DESCRIPTION	KEY	PART #	DESCRIPTION
		- STANDARD UNITS -			- REAR FLUSH UNITS -
1	FM806-6374SP	Clamp Assembly	n/s	FM823-2231	Drain Outlet Section, Closed, 15.86"L
2	FM816-0420	Boot, Connection Seal	10	FM823-2198	Full Vat Right End Section, 7.89"L
3	FMKIT-0257SP	Clamp Assembly and Seal Kit	12	FM823-2223	Drain Outlet Section, Full, 23.38"L
4	FM826-1382	Wing Nut	13	FM823-2207	Full Vat Drain Outlet Section, Open, 23.38"L
5	FM811-0932	Teflon Vent Tube, 3/8"	15	FM823-2233	Full Vat Drain Section, 15.39"L
6	FM810-1372	Vent Tube Fitting, 90°	n/s	FM823-2198	Full Vat Right End Section, 7.89"L
7	FM816-0135	O-Ring, Round Drain, 1-5/8"	5	FM811-0932	Teflon Vent Tube, 3/8"
8	FM823-2445	Full Vat Left End Section, 7.95"L			
9	FM823-2197	Full Vat Left End Section, 7.95"L			
n/s	FM823-2211	Full Vat Drain Outlet Section, Closed, 18.60"L			
11	FM823-2200	Full Vat Drain Outlet Section, Open, 23.38"L			
14	FM823-2301	Full Vat Drain Section, 15.39"L			